

Tenderizer

- for pork, beef, chicken, and turkey



Process description

Using a tenderizer is an effective way of opening muscles and thereby increasing meat surfaces. This is essential to increase the absorption capacity of meat and thus the possibility of improving assimilation of additives and subsidiary substances. In the succeeding processes, the quantity of muscle proteins on meat surfaces is substantially increased.

Working process

1. Products are conveyed on a belt and drop into knife rollers, one of which is spring-activated.
2. Knives open muscle fibres, thereby enlarging meat surfaces.

Advantages

- The roller distance is adjustable to compensate for overlaps or the distance between knives.
- A blind roller can be installed for products with rind.

Hygiene

- Super-effective cleaning as the SFK Tenderizer is equipped with a knife roller, each individual knife of which has six calibrated spacers. This means that the roller itself has an open structure, contrary to ordinary knife-roller tenderizers in the market. The open structure reduces daily cleaning by two hours compared to conventional types.
- Quick-lock system for conveyor cleaning.
- The tenderizer has a built-in retainer for easy handling of rollers during cleaning.

Safety

The tenderizer conforms to the strictest rules regarding health and safety.

Preconditions

Only for boneless products.

Legal preconditions

The tenderizer is CE-marked and complies with the HACCP regulations.

Specifications

- Max product height 80 mm
- Knife diameter 109 mm (standard)
- other knife sizes available
- 133 knives
- AISI 304 stainless steel
- Protection degree: IP65
- Glass-bead blasted surface
- Motor/gear transmission, 1.5 kW



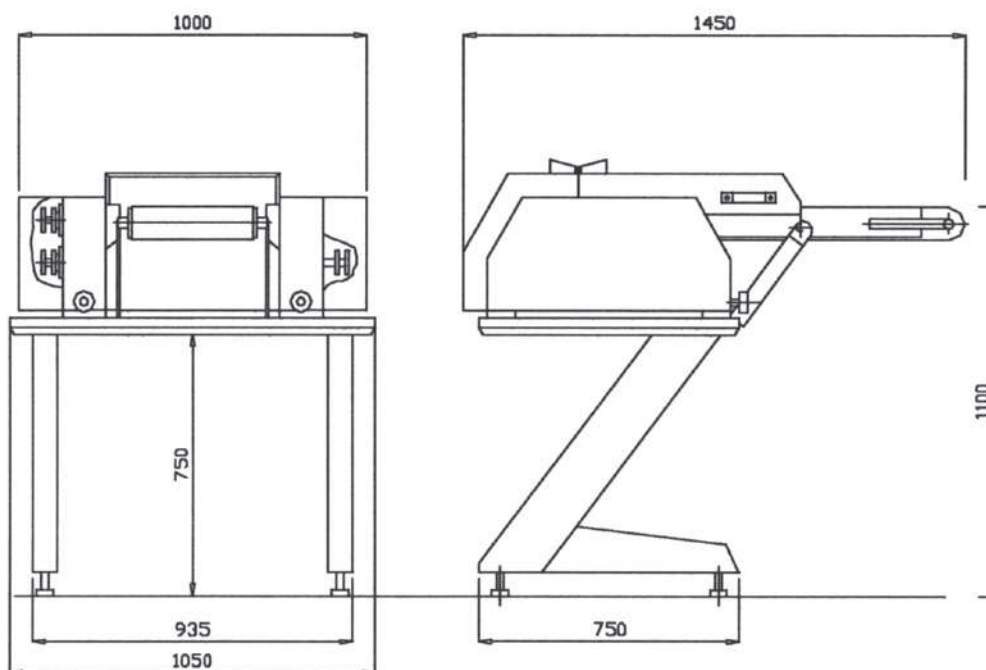

Technical data KT110 (KT140)

Kapacitet Capacity Kapazität	Up to 5,000 kg/hour (up to 10,000 kg/hour)	Arbejdsbredde Working width Arbeitsbreite	350 mm (550 mm)
Max. produkthøjde Max. product height Max. Produkthöhe	80 mm	Motor Motor Motor	1.5 kW (3 kW)
Antal knive Number of knives Anzahl Messer	133 pcs (153 pcs)	Spænding Voltage Spannung	3x220/400/415/460
Kniv, diameter Knife, diameter Messer, Durchmesser	109 mm (138 mm)	Styrespænding Control voltage Steuerspannung	24 VAC
Knivvalseafstand – indstillelig Knife roller distance – adjustable Messerrollen-Abstand - einstellbar	-6 to +20 (-10 to +16)	Vægt, netto Weight, net Gewicht, netto	Approx. 300 kg (Approx. 500 kg)

Tal i () = KT140 - Numbers in () = KT140 - Zahlen in () = KT140
 Technical data subject to alteration / Technische Änderungen vorbehalten.

SFK Systems A/S

SFK Systems A/S · Indkildevej 2-4 · DK-9210 Aalborg SØ
 Tel. +45 7634 2700 · Fax +45 9814 9290 · mail@sfk.com · www.sfk.com